

# Control System of an off-grid Micro Hydro Power Plant

Priyanka Malhan<sup>1</sup> and Naresh Kumar<sup>2</sup>

(Student M.Tech) Department of Electrical Engineering, Deenbandhu Chotu Ram University of Science and Technology

<sup>2</sup>Deenbandhu Chotu Ram University of Science and Technology  
E-mail: <sup>1</sup>priyankamalhan93@gmail.com, <sup>2</sup>nareshkumar.ee@dcrustm.org

**Abstract**—Electricity is the dire need of the growing world. It is utmost important to ensure uninterrupted power supply to the end users and is a major concern of the power utilities. But In the hilly areas and various such remote locations it is very difficult to reach out through a national grid. Therefore Micro Hydro Power Plants can be presented as an energy solution for the remotely located small towns and villages. Micro Hydro Power Plant (MHPP) is one of the best ways to harness the available energy of water in the form of electricity. But there are certain issues when it comes to enough power generation from small hydro plants like MHPP. One such problem is the water discharge or water flow rate available to generate power. The water discharge at the potential sites is small and this discharge is continuously fluctuating and variable which in turn affects the output power generated from the MHPP. This paper presents a control system approach for the off grid MHPP to extract maximum amount of electrical energy from the available potential energy of water in such a way that the generated power remains constant irrespective of the fluctuations in the water flow rate.

## 1. INTRODUCTION

MHPP is a type of hydro plant that can generate power from 5KW to 100KW or up to 1 MW. MHPP construction is generally run-of-river type as it requires very little flow to power the turbine. Initially water is directed from the river towards the pipeline called Penstock via the weir and the open channel. The penstock maintains the required head for power generation. From penstock the water is headed towards the Power house building which contains the hydraulic turbine and generator assembly. The turbine thus converts the flow and pressure of water into mechanical energy required by the generator to produce electricity. The schematic diagram of micro hydro power plant is shown in Fig. 1[4]. There are numerous examples of micro hydro projects which are successfully running and thus provided a technique which encourages the most reliable and efficient use of energy. The potential sites for MHPP in India include major areas of north-eastern zone such as Jammu & Kashmir, Himachal Pradesh, Uttarakhand, Arunachal Pradesh, Haryana etc. Sumoor is the only micro hydro project that is commissioned in J&K with an installed capacity of 0.1 MW. Apart from India, Nepal also

has huge potential of developing power from micro hydro projects. Nepal is rich in water resources. It has enough water to electrify the entire country of 27 million people. UNDP in Nepal has undertaken the micro hydro project implementation task. Since 1996, 400 micro hydro plants are built serving power to around 500,000 people. The average micro hydro project provides about 30 KW of power, enough to power the village like Karbang and Kathmandu. IBEKA (Indonesia) won 2012 Ashden Award for its success in developing off grid hydro projects ranging from 0.5 KW to 170 KW. Due to which greenhouse gas emissions are reduced by 7400 tonnes per year of carbon dioxide.

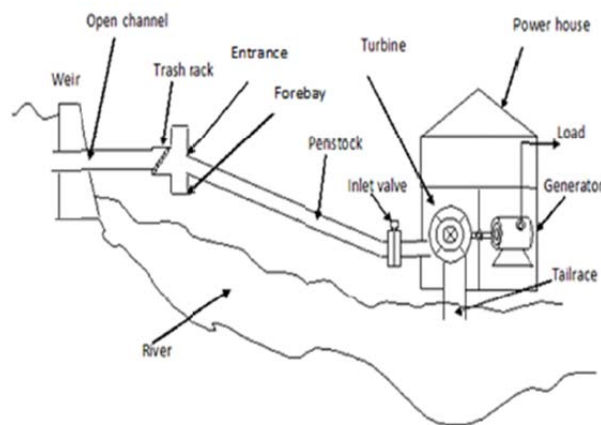

Fig. 1: Schematic diagram of micro-hydro electric power plant

## 2. BENEFITS OF INSTALLING MHPP IN REMOTE AREAS

- Provides cost effective energy solution
- No reservoir or construction of dam is required
- It will prove more economical than any other renewable energy source as the resource is reasonably close to the end users.

- Efficient and reliable source of energy as it requires only two gallons per minute to generate few KW of power.
- These plants run 24 hours a day unlike the solar and other renewable sources of energy.
- Requires lower maintenance practices and it is done at the ground level.

**3. BASIC CONTROL SCHEME FOR MHP**

The control scheme proposed for the MHPP is described by block diagram which is shown in the Fig. 2. The conventional hydraulic governor system to control the discharge of water to turbine is used in large hydro plants. These cannot be used at micro hydro level as it would make the system more complex. This would also require heavy maintenance and is expensive to be used at such small level. Therefore, it is uneconomical to use the conventional system as the controlling mechanism.

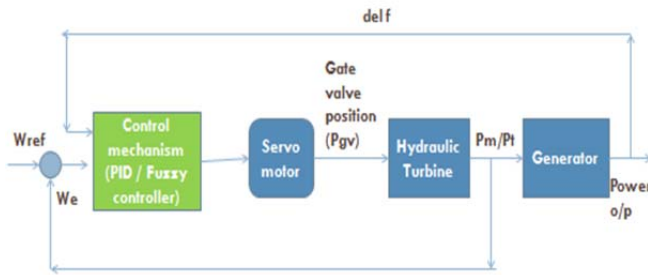

**Fig. 2**

The power generated may experience fluctuations whenever there are load fluctuations. So, nowadays Electronic Load Controllers (ELCs) are installed at the control room to maintain a constant electrical load on the generator. The ELCs control the load fluctuation by artificially adding or subtracting the load on the generator as per the requirement.

A controlling valve is installed at the hydraulic turbine to regulate the flow of water to the turbine. This valve is operated by Servo-motor and the operation of the servomotor thus can be controlled to control the variable flow of water. In this paper the controlling valve is considered as the gate valve. The parameters used in the Fig. 2 represent the following:

Wref = reference speed

We = actual turbine speed

Pm/Pt = Mechanical power/Turbine output power

Pgv = position of the gate valve

delf = change in frequency

**1. Analysis of Turbine power (Pt) with variable Flow (Q) and Gross Head (H)**

The water flow rate (discharge) measurement:

$$Q = A_r * V_r \text{ ( m}^3 \text{ / sec)}$$

Where  $A_r$  = cross-sectional area of the river

$V_r$  = average flow speed

$$V_r = V_{rs} * 0.75 \text{ (m/sec)}$$

$$V_{rs} = L / t \text{ (m/sec)}$$

Where  $V_{rs}$  = surface speed (m/sec) [4]

Head measurement [4]:

The gross head (H) is the vertical distance between the water surface level at the intake and at the tailrace for the reaction turbines and the nozzle level for the impulse turbines. The GPS (Global Positioning System) can be used to measure the gross head available at the site. Once the gross head is known the net head can be calculated easily by subtracting the losses from the path.

Turbine power measurement (Pt):

The power output in the hydraulic turbine generator system depends mainly upon the available head (H) and the flow rate (Q). In order to have an effective power output either the head should be high or the flow rate.

$$P_t/P_m = \rho * g * H * Q * \eta_t \text{ (watt)}$$

Where  $\rho$  = water density (1000Kg/m<sup>3</sup>)

g = acceleration due to gravity (9.8 m/s<sup>2</sup>)

$\eta_t$  = turbine efficiency (normally 80-90%)

The turbine efficiency is defined as the ratio of power supplied by the turbine to the absorbed power. [4]

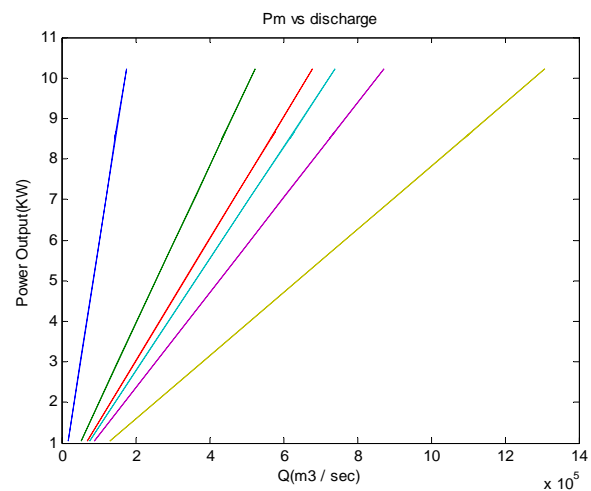
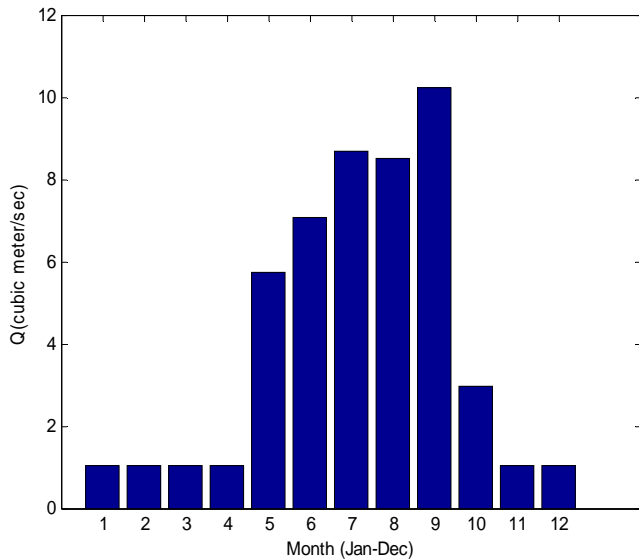

**Fig. 3**

The variation of mechanical power with variable flow rate at different values of gross head is shown in the Fig. 3. The monthly discharge of river for the potential site must be estimated to analyze the behavior of mechanical power with the variable flow rate. The source of required data for the analysis is Energy Utilization Management Bureau.

**Table 1**

Month	Monthly Discharge of the river (m3/sec)
January	1.03
February	1.03
March	1.03
April	1.03
May	5.72
June	7.07
July	8.69
August	8.51
September	10.22
October	2.96
November	1.03
December	1.03



**2. Control System model of MHP**

The control system model of MHP presented in this paper is created using MATLAB/Simulink software. The block diagram of the model is shown in Fig. 4. The flow rate of water is controlled using the PID controller. The PID controller regulates the operation of the servomotor and the servomotor maintains the gate valve position constant. Thus water Discharge (Q) would be made to rise to its peak value in a short period of time and attains a constant position after that. Therefore, maximum possible mechanical power is produced as per the relation:

$$P_m/P_t \propto Q$$

It would result in full utilisation of the available energy of water.

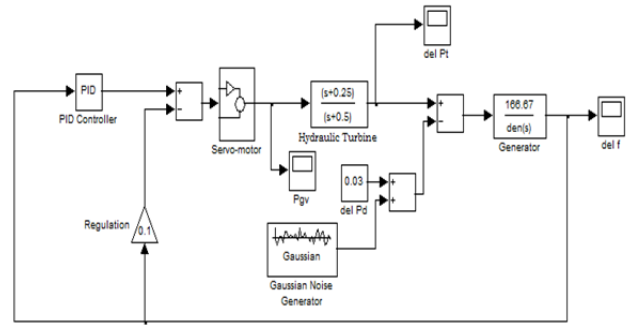

**Fig. 4: Proposed model of MHP**

**PID Controller:**

PID controllers are used to study the time domain characteristics of various parameters of power plant since these controllers possess control loop feedback mechanism. It improves the output response by minimizing the error in system. The transfer function of the controller is shown below [1]:

$$K(s) = \frac{v(s)}{e(s)} = (K_p + \frac{K_I}{s} + K_D s)$$

Where,

e(s) is the controller input

v(s) is the controller output

**Model of servo-motor:**

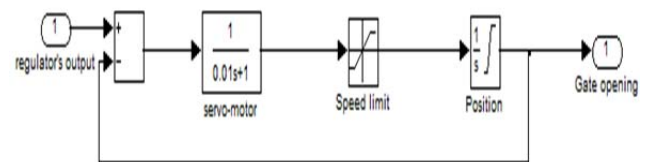

**Fig. 5: Simulink model of servo-motor**

Servo-motor performs the function of governor in the proposed model of micro hydro power plant. It allows precise control of linear or angular position in closed loop control system. The motor requires specific sophisticated controller which can provide either analog or the digital signal input. Here PID controller fulfills the purpose. The servo-motor consists of suitable motor coupled to a sensor for position feedback. Generally DC servo-motor is used to maintain the controlled variable constant at a certain desired value despite disturbance. [1]

### Load Disturbance modeling [1]:

The proposed model in the paper is subjected to two types of disturbances. The first type is a simple step increase in load. The value chosen for this type of disturbance is 3 percent as it is desired that the magnitude of disturbance is comparatively higher than the loading at small scale power generation such as MHP. [3] The second type of disturbance is stochastic disturbance. It is introduced in the system by random switching on/off of the appliances by the users. To model this random switching operation, independent of each other, Gaussian disturbance is used in the model.

## 4. RESULTS AND DISCUSSIONS

The proposed control system of MHP results into a linear relationship between the mechanical power output and the variable water flow rate as shown in Fig. 8. The power output reaches to its maximum value when the variable flow rate becomes constant. The variation of water flow rate with time is presented in Fig. 7. It explains clearly that the gate valve position can be controlled to maintain the discharge (Q) constant at its maximum value. Thus it would result into optimum amount of power generation which can be seen in Fig. 6.

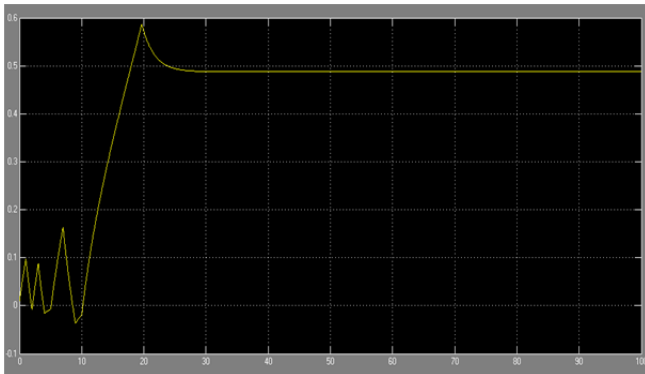

**Fig. 6: Variation of Mechanical Power output (Pt/Pm) in p.u. with time in sec**

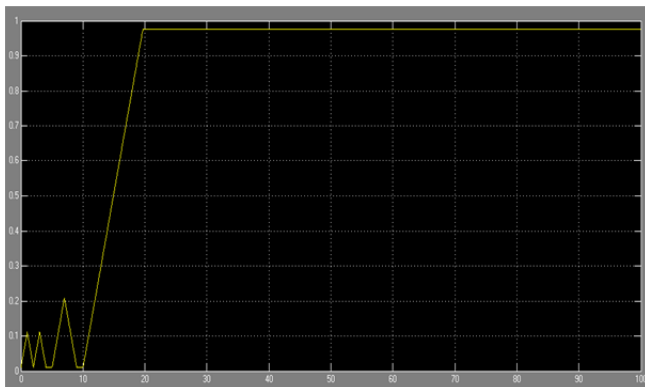

**Fig. 7: Variation of Gate valve position (Pgv) with time in sec**

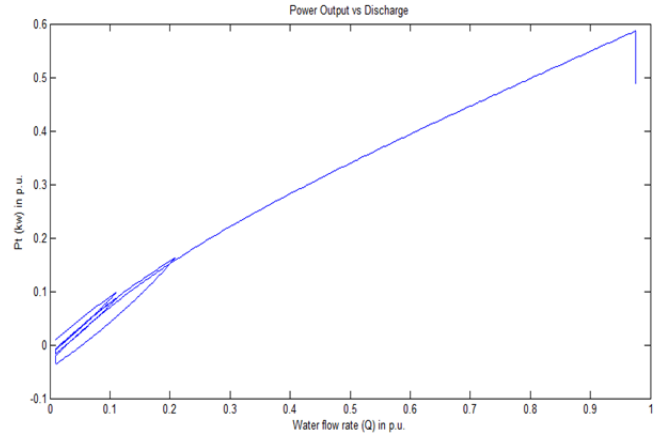

**Fig. 8: Power output (Pt) vs Discharge (Q)**

## 5. CONCLUSION

This paper explains that water can be smartly utilized to generate enough power for those who cannot easily access it. The control system approach thus used maintains the water discharge constant at its maximum value. Further different controllers can be used to analyze the behavior of output power generated for variable water flow rate and head. This approach will prove very beneficial in case of load fluctuations and other disturbances in the system.

## REFERENCES

- [1] Goyal, Himani, Hanmandlu, M., and Kothari, D.P., *An Artificial Intelligence based Approach for Control of Small Hydro Power Plants*, Centre for Energy Studies, Indian Institute of Technology, Hauz Khas, New Delhi, India, 2005.
- [2] Goyal, H., Bhatti, T.S., and Kothari, D.P. A novel technique proposed for automatic control of small hydro power plants, *International Journal of Global Energy Issues*, 24 (1/2), 2005, pp 29-46.
- [3] Harvey, A., Brown, A., Hettiarachi, P. and Inversin, A., *Micro Hydel Design Manual, A Guide to Small Scale Water Power Schemes*, (Intermediate Technology Publications, 1993).
- [4] Nasir, Abdullah, Bilal, "Design of Micro Hydro Electric Power Station", *International Journal of Engineering and Advanced Technology (IJEAT)*, 2, 5, June 2013, pp. 39-42.
- [5] Lone, Ahmad, Rayes, "Modeling and Analysis of Canal Type Small Hydro Power Plant and Performance Enhancement Using PID Controller", *IOSR Journal of Electrical and Electronics Engineering (IOSR-JEEE)*, 6, 2, May- June 2013, pp. 06-14.
- [6] [www.ashden.org/winners/IBEKA12](http://www.ashden.org/winners/IBEKA12)
- [7] Department of Energy, Energy Utilization Management Bureau, *Manuals and Guidelines for Micro-hydropower Development in Rural Electrification*, 2, 2009.